

**SOLIDWORKS
WORLD 2011**

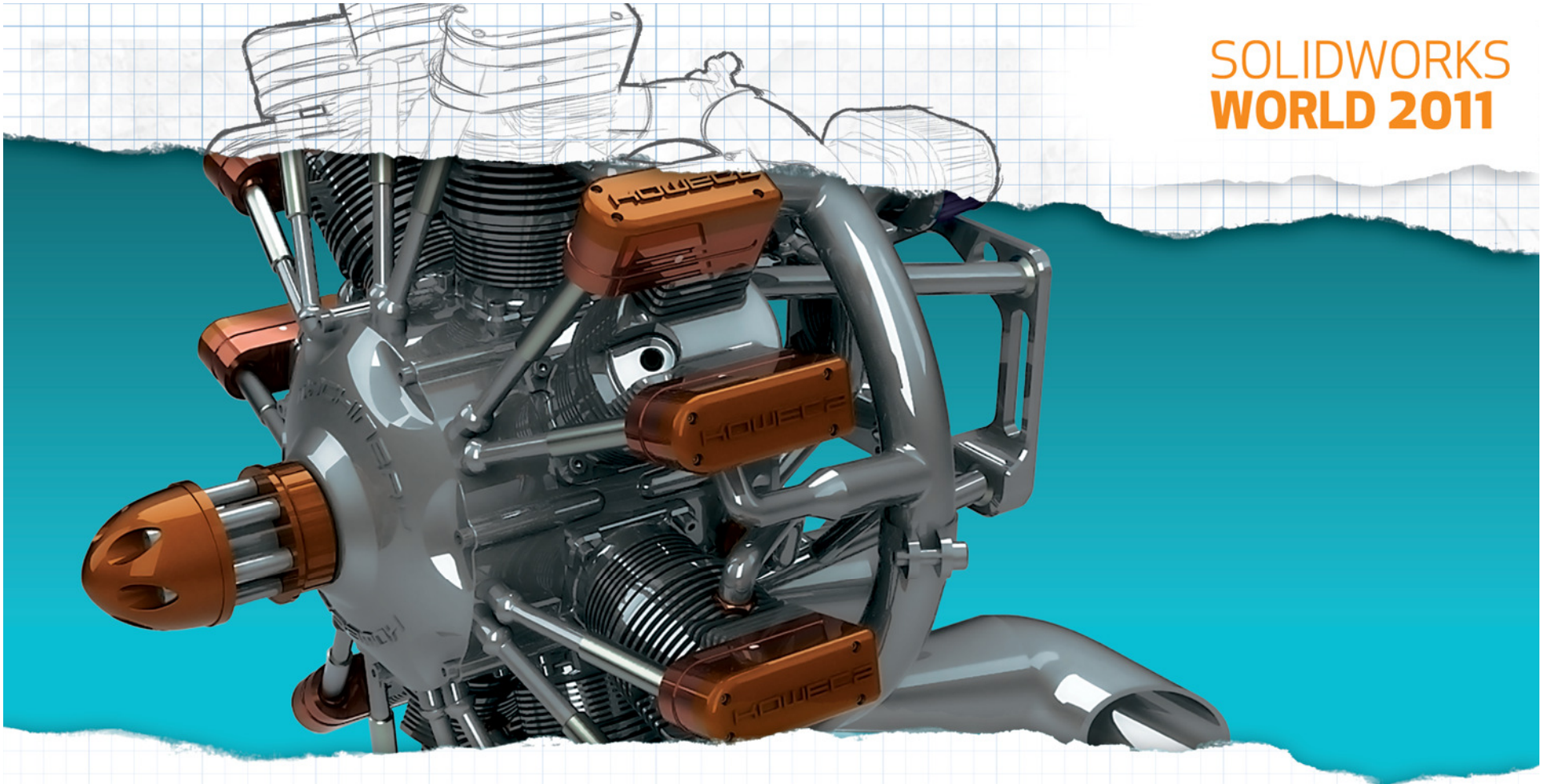

Creating Robust Top-Down Assemblies in a Collaborative Design Environment

Ben Nibali, President (BSME)

Aaron Carroll, Mechanical Designer (BSME)

Kris Hall, Mechanical Designer (BSME)



Presentation Contents



SOLIDWORKS
WORLD 2011

1. Introduction to Top-Down Design
2. Introduction to Driving Sketches
3. When to implement Driving Sketches in the Design Process
4. Examples and Demonstration:
 - Simple Assembly Model using Driving Sketches
 - Complex Assembly Model
 - Simultaneous Collaboration in a Complex Assembly
5. Tips for Robust Modeling:
 - General Assembly Modeling “Best Practice”
 - Top-Down Modeling “Best Practice”
 - SW “Layout” Function
6. Justification: Controlling the Impact of Late-Stage Changes

Technical Session Prerequisites:

1. Intermediate SolidWorks User
2. Some knowledge of Top-Down vs Bottom-Up Design

Introduction to Top-Down Design

Example: This 3-part assembly must always have a total height of 20 inches. Base and Spindle may change.

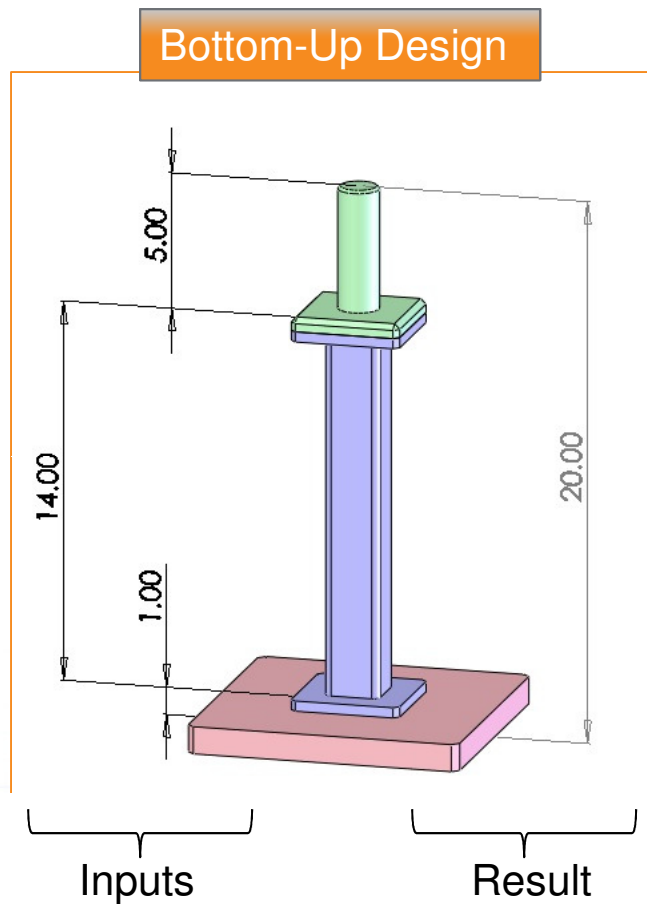

Total Height is a Result

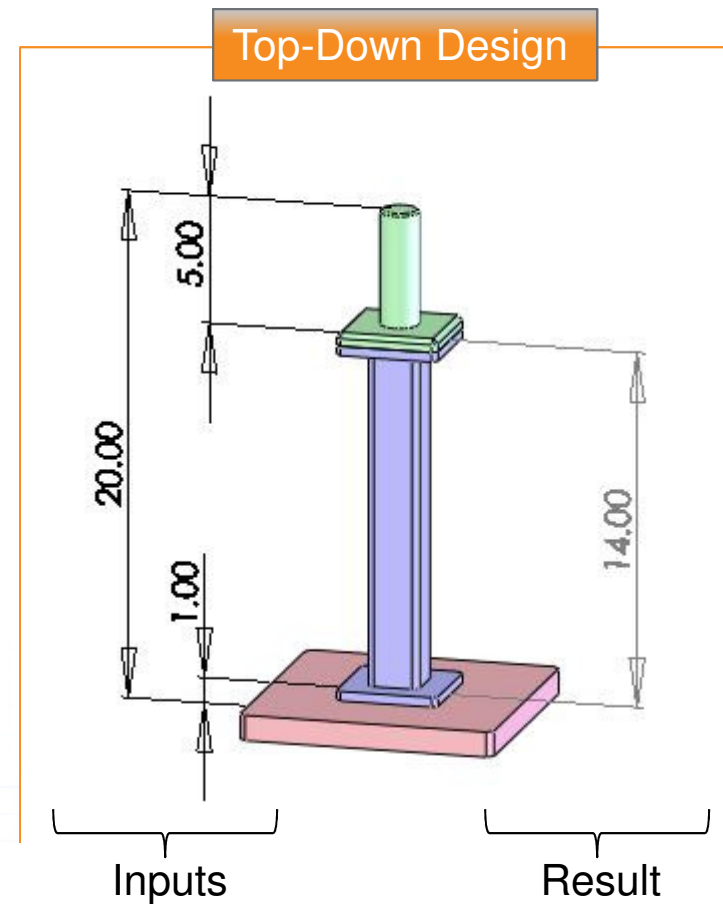

Total Height is an Input

Use Top-Down design to create assembly models that respond logically to changes.

Introduction to Top-Down Design using “Driving Sketches”



SOLIDWORKS
WORLD 2011

Ultimate Goal: Creation of “robust” assembly models that can be modified (within a reasonable range) in the future without error or inefficiency. Time invested in early-stage model setup will reap rewards when late-stage specification changes or optimization are required.

The need to make changes efficiently in the future justifies a special approach:
Think of the assembly model as a “machine” that must have clear, consistent controls. Precise desired behavior should result from simple, logical input. Assume that others will need to learn to use this machine after you have moved on to other things. Assume that you will not remember how it works.

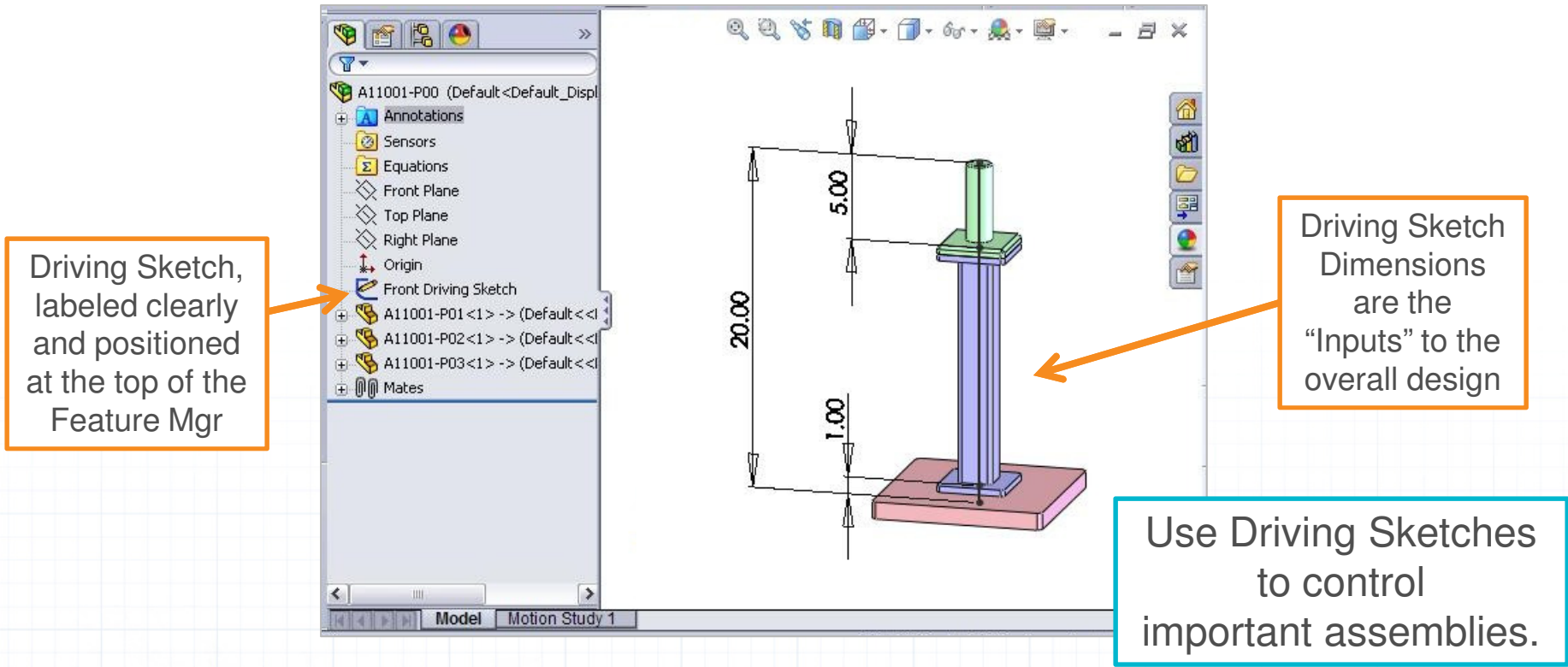

When to implement “Driving Sketches” in the Design Process

In the real world, the design process is often nonlinear and unpredictable. Any practical modeling strategy must be flexible to deliver design efficiency in spite of changes to “the specification”.

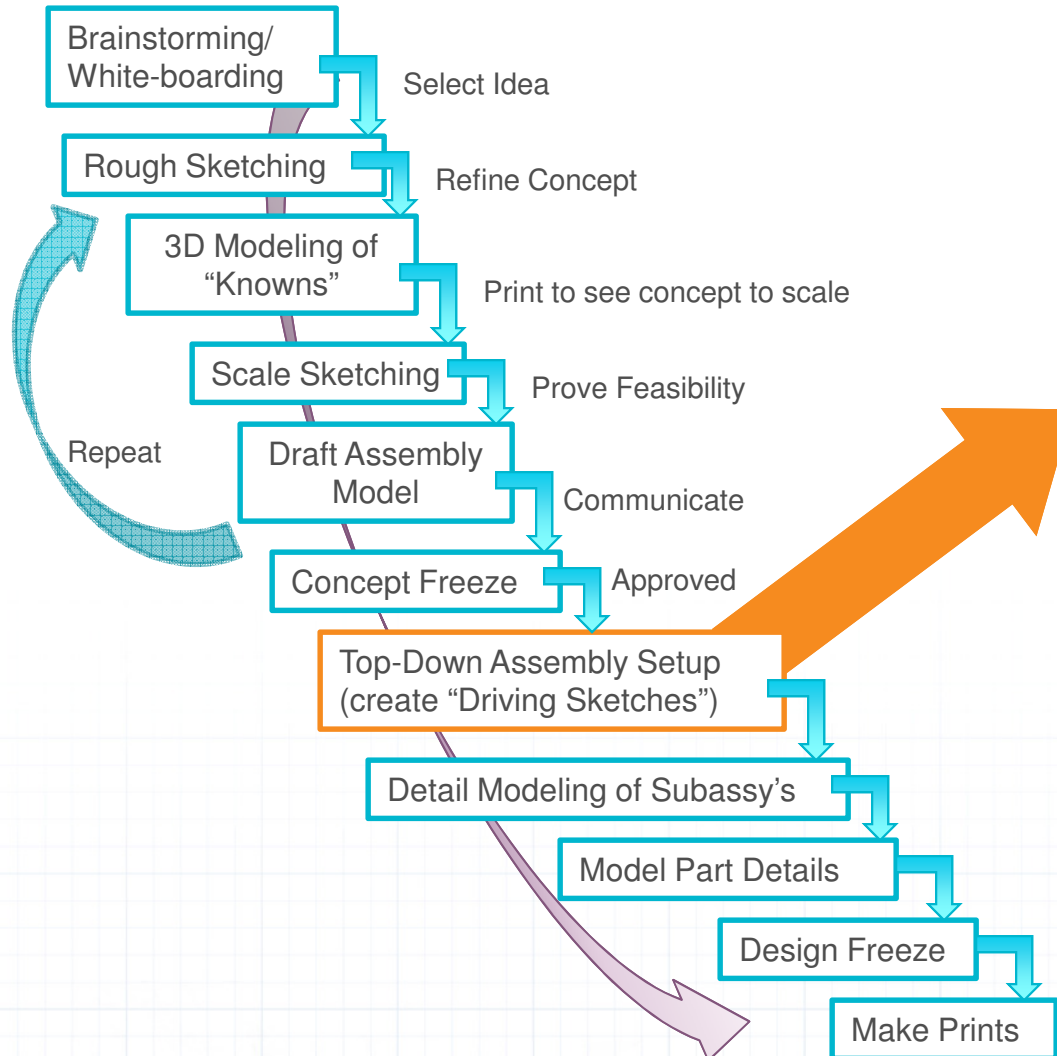

Top-Down Assembly Setup:

Create “Driving Sketches” to control assembly model(s) for the remainder of the design process.

Start Over when model includes complex geometry or needs major changes compared to draft assy.

-or-

Apply to Draft assembly model if the relationships are simple and draft parts are close to final shape.

- Insert Driving Sketches into the Feature Manager just below “Origin”
- Label them clearly as “Top Driving Sketch”, “Front Driving Sketch”, etc.
- Create other driving geometry (planes, axis, etc.) as needed

Example: Simple Assembly Example controlled by Driving Sketches

This example shows a simple table controlled by two Driving Sketches. The basic design is controlled quickly and intuitively from the driving sketches. Minor part-level features are controlled in the part files.

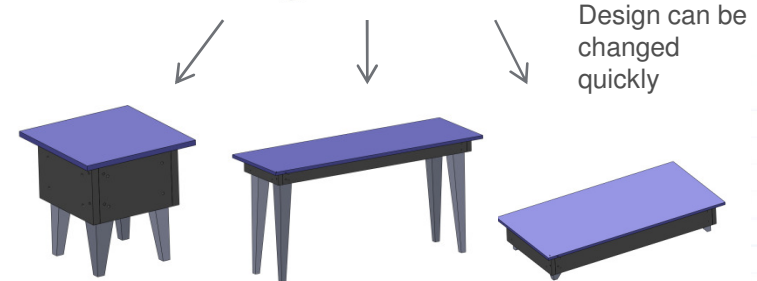
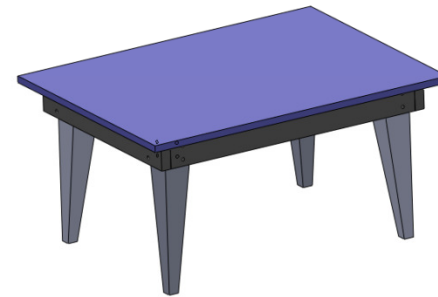
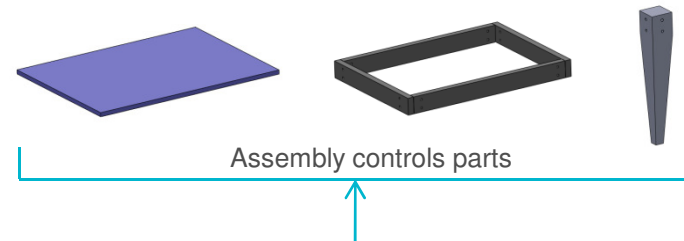
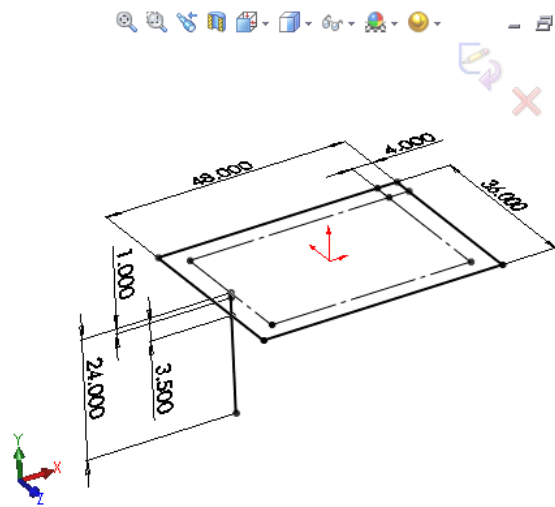
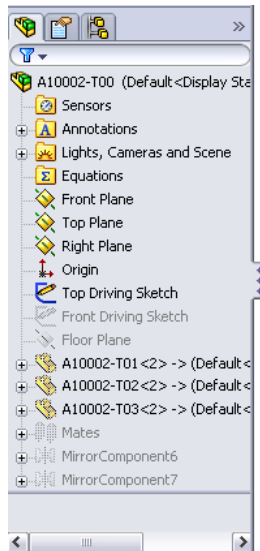

Top-Down Part Setup:

“Driving Sketches” and other reference geometry can be made to control existing part features:

- Update primary plane locations and names
- Re-mate component into the assembly using Driving Sketch(es) and reference geometry
- Delete controlling “input” dims in features and Re-constrain features to Driving Sketch(es) and other geometry

Example: Complex Assembly Model

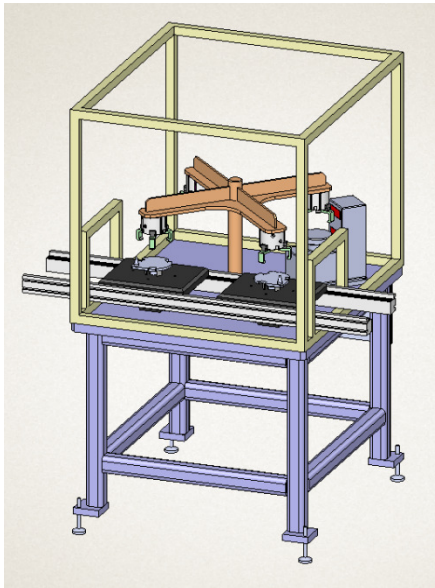

Assembly Structure

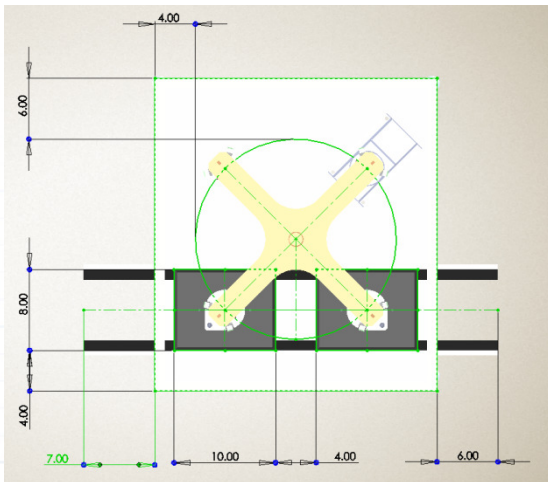

A00 Assembly



A01

A02

A03



B00 Sub-Assy



B01

B02

B03



C00 Sub-Assy



C01

C02

Gripper Sub-Assy

G01

G02

D00 Sub-Assy



D01

E00 Sub-Assy



E01

E02

External References:



SOLIDWORKS
WORLD 2011

How External References Work in SolidWorks:

- An Assembly may reference any external data.
- A Part can only* have external references in the context of a single assembly. All data in that assembly (including any subassemblies) is available to be referenced.

*as SolidWorks is configured by default

Creating unstructured ExRefs in a complex nested assembly causes confusion about where the “controls” are for each part

Creating a tangle of ExRefs between parts and assemblies reduces collaboration flexibility.

Our Rules for Controlling ExRefs:

1. A Part's external references should only be in the context of the assembly that the part is instanced in.
2. When a part needs to reference data that is not contained in (or under) its In-Context Assembly, pass the data between assemblies using a Driving Sketch or other labeled reference geometry.

Example: A Part ExRefs outside of its Assembly

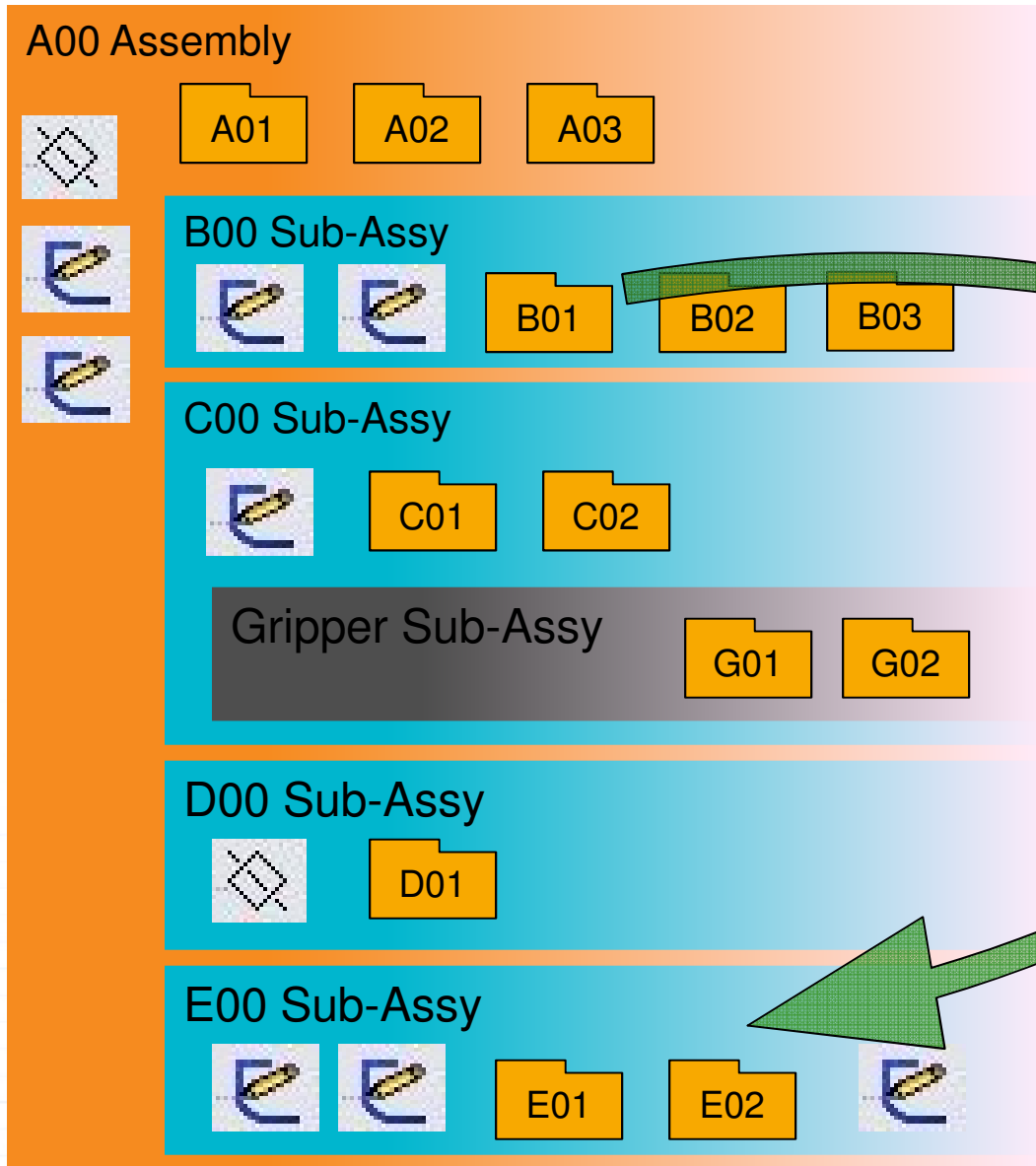

Part B01 References
Geometry in Sub-Assy E00

Result:

- Part B01 is now “married” to Assembly A00 for ExRefs
- Designer must have write access to both A00 and B00 to create new ExRefs
- Collaboration options reduced

Example: Part's ExRefs stay within its Assembly

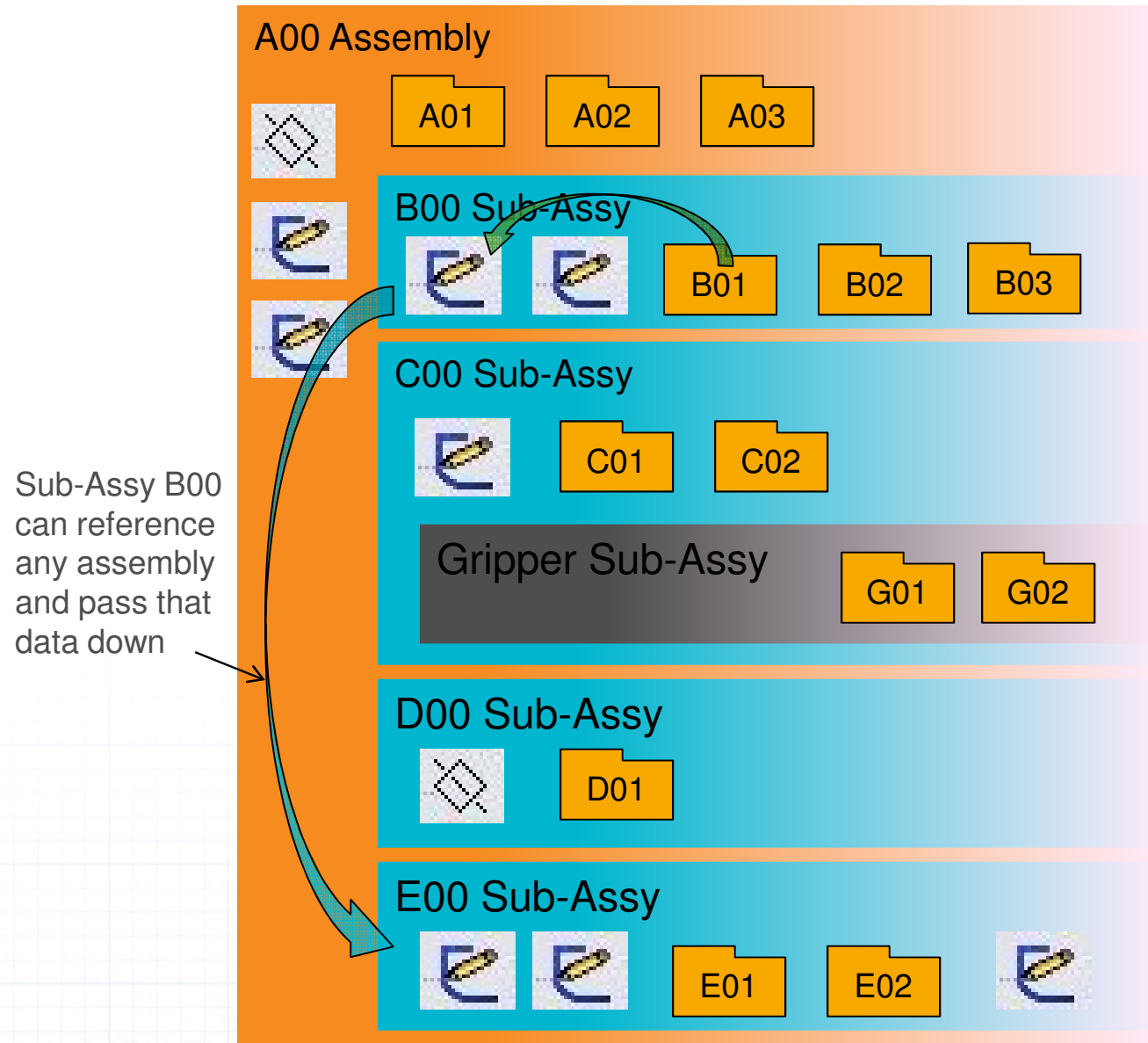

Part B01 References Geometry copied into Sub-Assy B00

- Result:
- Part B01 is now “married” to it’s own sub-assy for ExRefs
 - Designer needs only B00 to create new ExRefs
 - Collaboration options wide open B00 sub-assy

Nested Assembly with Controlled ExRefs

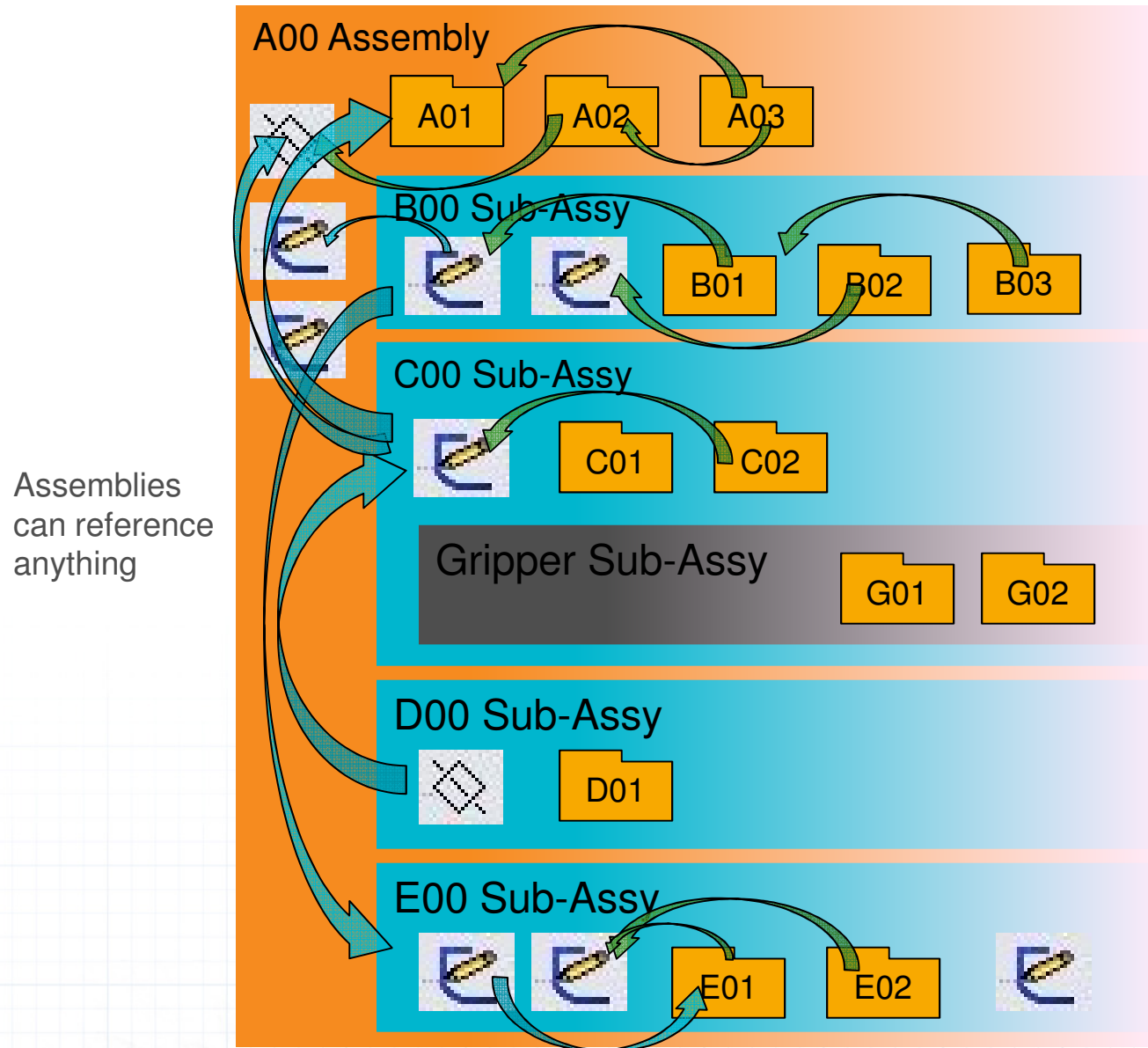

Assemblies can reference anything

All Parts Reference Geometry within their own Sub-Assy

- Result:
- All Parts now “married” to their own Sub-Assy for ExRefs
 - Designer needs only a single Sub-Assy to create new ExRefs
 - Collaboration options wide open for this nested Assembly

Example: Collaboration Enabled by Robust Top-Down assembly model

Robust Top-Down design enables improved design management options through efficient collaboration:

- Increase capacity when needed with simultaneous distributed design
- Shift assemblies smoothly between designers for increased flexibility
- Effectively implement legacy work into new projects with reduced learning curve

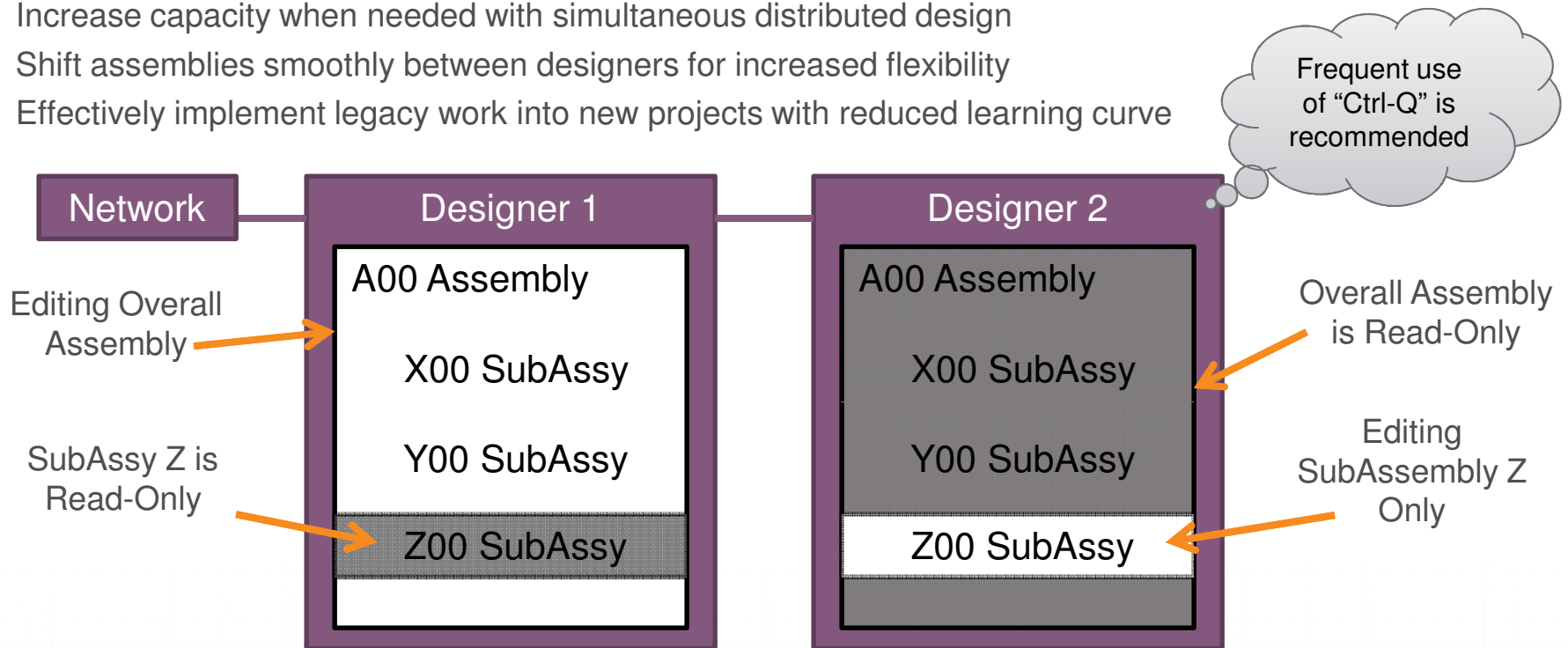

- Use File-Reload to release or gain write access to a part or subassembly as needed (click "Show References" to change read/write status of any file in an assembly)
- Enable Multi-User Environment to have SW prompt you when changes have been made to any read-only file

Note: This type of collaboration is possible without Robust Top-Down techniques... but predictable model behavior and Xref flexibility is reduced.

Recommended Procedures: **Assembly Modeling** Best Practice for a Collaborative Design Environment



SOLIDWORKS
WORLD 2011

- Organize your FeatureManager: Reference geometry at the top, subassembly's and parts in order or grouped logically. Create folders as needed so that entire menu is visible at once when collapsed.
- Component and Subassembly models should be created such that Top/Front/Side planes are useful for mating at the next higher assembly level.
- By default, Top/Front/Side plane orientation should be consistent among components of an assembly.
- Rename Top/Front/Side planes in parts and subassemblies if helpful to clarify their significance.
- Retain item type as part of the name when re-naming items for clarity.

“Sketch1” -> “Top Driving Sketch” “PLANE1” -> “Mount Plane”

- All parts should be fully mated. The 3 principle mates should be at the top of the “Mates in (assy)” list.
- Mate major components using reference geometry (planes, axes, etc. defined by primary geometry or Driving Sketches) instead of faces, edges, or vertices. These feature-level definitions can change and this often creates confusing mate errors later. Note: we generally do not apply this rule to purchased components or standard hardware.

- Avoid redundant (or partially redundant) mates. This will often result in a false “Conflicting Mates” error.
- Avoid “Virtual” (in-context) parts in your assemblies. They do not handle assembly file name changes well.
- Avoid “Width” mates. They encourage the selection of faces for mating and can reverse direction unexpectedly. Instead create reference planes in each component and make them coincident.
- Avoid “Fix” and “In-Place” mates. These are not robust, logical mates.
- Avoid duplicating related dimensions. Enter the value once and create a relationship in the assembly.



Use Top-Down Modeling...

Recommended Procedures: Top-Down Modeling Best Practice for a Collaborative Design Environment



SOLIDWORKS
WORLD 2011

Use simplest Driving Sketches possible, with only significant controls included in each assembly. Shift control down to subassemblies when possible.

- Driving Sketches include: interfaces (faces, axes) between assemblies, major interfaces between parts in the assembly, stroke lengths, clearance limits, boundaries, etc.
- Don't include: isolated items (items that influence only a single part) such as feature sizes, material thickness, etc. Don't include fastener hole locations, etc. that are most logical as a part-to-part relationship within the assembly.

Consistently and clearly label controls:

- For sketch: "Front Driving Sketch" instead of "Sketch1"
- For reference geometry such as plane, axis, etc: "INPUT: Limit Plane" instead of "Plane1"
- For equation variables: "INPUT: Flange Thickness" instead of "t"

•Do not let parts Xref outside the assembly they are instanced in. This often leads to confusion later and can cause collaboration inefficiencies. If needed, let the part reference a local Driving Sketch or other reference geometry containing the relevant data from the other assembly.

•Avoid using dimensions for positioning parts or features if some input geometry is really driving the design. If you are measuring your model and calculating a number to enter as a dimension, there is often a geometric control opportunity. If you find yourself repeatedly tweaking a number to help you achieve a specific result elsewhere in your model, the driving sketch logic may be faulty.

•Avoid duplicating related dimensions. When practical, enter the value once and create a relationship in the assembly to maintain a single input point.

SolidWorks “Layout” function

Always use the simplest Driving Sketch possible...

Always clearly label the Driving Geometry....

Therefore:



Avoid using the built-in “Layout” function (the rabbit hutch).



Unnecessarily complex and confusing, often hidden, and impossible to label clearly. Layout sketch constraints appear in the Feature Manager as assembly mates, causing confusion.

From SW Help: *“The major advantage of designing an assembly using a layout sketch is that if you change the layout sketch, the assembly and its parts are automatically updated. You can make changes quickly, and in just one place.”*

The intent is great. The problem is the “*just one place*” part, since the single controlling 3D Sketch will be complex if the assembly is complex. It is better to create multiple simple “Driving Sketches” that control related items, and that can be labeled appropriately.

What Have We Accomplished?

We know:

1. Top-Down is Powerful
2. Ability to collaborate (distribute load for simultaneous design by sub-assy) is Powerful

However, ExRefs power Top-Down design, and they tend to entangle sub-assemblies and cause confusion.

Therefore we structure our nested assemblies for clean separation of ExRefs, allowing clear and robust collaboration.

We deliver optimized design and high efficiency.

Rapid changes of geometry-driven features in multiple parts & subassemblies

Driving Sketches are the controlling inputs to the model, reducing the risk of confusion and enabling collaboration

Reference Geometry is the intermediary thru which to pass Xrefs. This allows components to indirectly "reference" more than one assembly

Specification changes can result in changes to the Driving Sketches (not just adjustment of the input values.) Ex.: Changing the overall width control of a machine.

Robust Top-Down Modeling makes the Assembly:

FAST

STABLE

CLEAR

POWERFUL

LOGICAL

Justification: controlling the impact of late-stage design changes

Significant late-stage design changes are often the result of “Specification Change” (even when there is no formalized “specification”).

Late-stage changes are also required in order to perform design Optimization throughout the project.

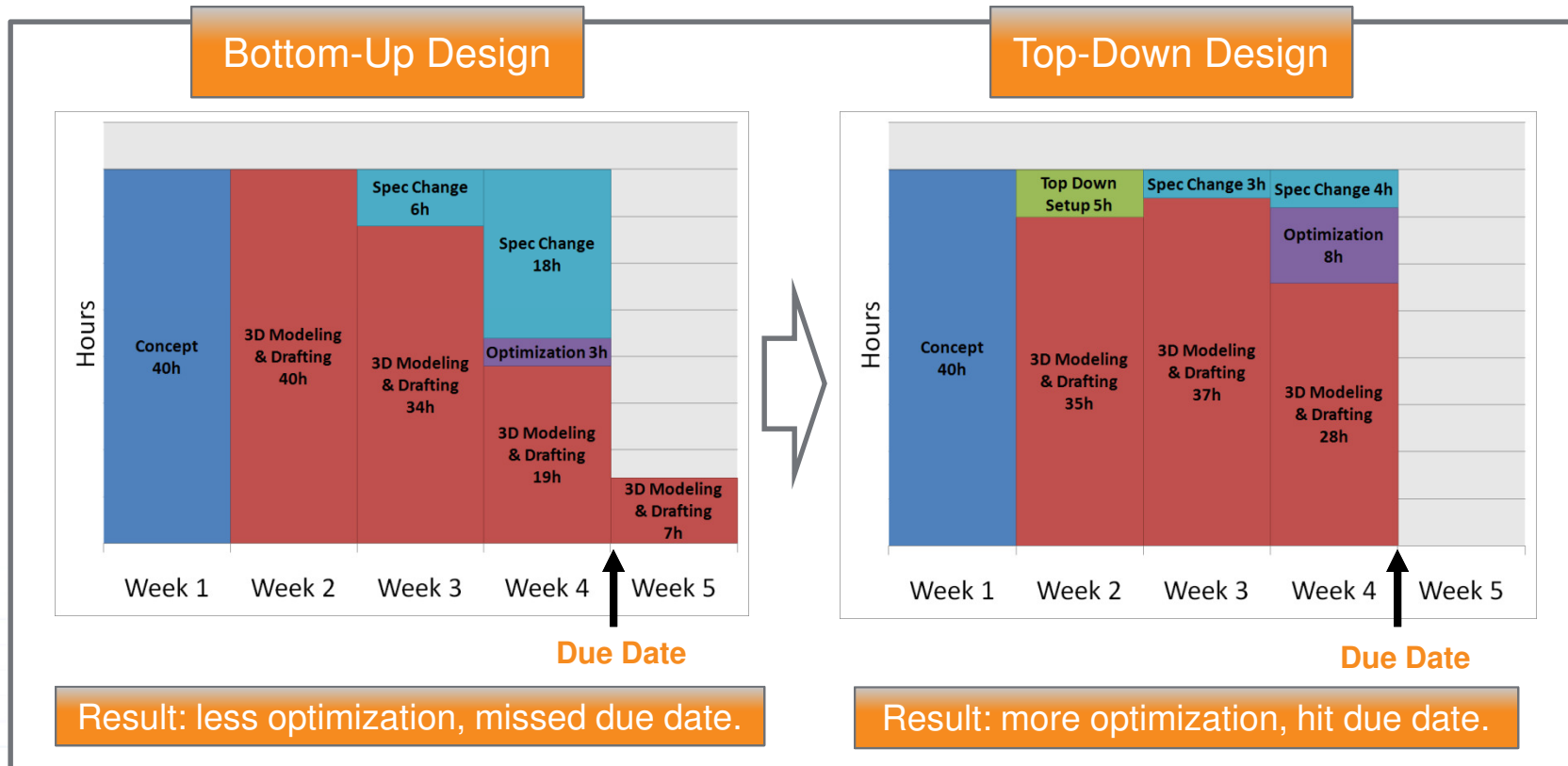

Optimization (design quality) and schedule control are the output variables sacrificed when design capacity is taxed by late-stage specification changes.

Conclusion



SOLIDWORKS
WORLD 2011

Presentation Materials and Example Model Files are available for download at:

www.iSolidWorks.com

Questions? Comments? Suggestions?